



# THE BOOM OF POLYESTER IN THE APPAREL AND SPORTSWEAR MARKETS

---

Why today's textile professionals are investing in dye-sublimation





1. **The boom in the athleisure industry**
2. **How polyester became a key technology**
  - a. Improvement in moisture transmission
  - b. Demand for customized products
  - c. Ease of printing
3. **Challenges in dye-sublimation printing**
  - a. Color accuracy
  - b. Nozzle outage
  - c. Paper cockling
4. **Toward technical solutions**
5. **Conclusion**
6. **References**



## The boom in the athleisure industry

If a textile printer had to choose just one fiber type on which to focus, it would inevitably be polyester. It's by far the world's most popular fiber; and among the many polyester market segments, the most dynamic in recent years has been sportswear, supported by its more fashion-conscious cousin, athleisure. Team sports, in particular, are the perfect fit for digital printing, demanding short runs and a high degree of personalization.

The fitness boom has led to a steady increase in sport participation and active leisure pursuit, especially among women. This year the global market for sportswear is expected to reach nearly US\$279 billion<sup>1</sup>, having grown at a 'healthy' average of 4.16% for each of the past five years.

And it doesn't stop at serious sport. These days, the boundaries between sportswear and fashion are blurred so that our wardrobes are full of casual, comfortable garments that would be equally at home on the running track as in the supermarket or the local café.



US\$279 bn<sup>1</sup> by 2020



4.16% average growth





# How polyester became a key technology

## 1. Improvement in moisture transmission

It may seem surprising that polyester came to dominate the sports-activewear market, given its intrinsically hydrophobic nature, which means it cannot easily transport moisture away from the skin to evaporate and keep the wearer cool and comfortable. This disadvantage is one of the reasons why it was frequently blended with cotton, and sometimes still is. But polyester fiber can now be made with a specific cross-section that boosts its moisture-transmission performance, and when that objection is removed, its ease of processing and easy-care qualities make it a clear winner. Add in the significant price advantage and it's no contest!

This trend is visible, not just in activewear, but also across high-street fashion. As recent as the year 2000, polyester and cotton had roughly equal shares of world fiber consumption. Now, more than twice as much polyester is consumed as its natural rival. Both fibers have their environmental critics, but an expanding market for polyester fiber made from recycled sources such as PET soda bottles points the way to a greener future.



**The ease of processing, easy-care qualities and pricing of polyester make it a clear winner for these industries.**

## 2. Demand for customized products

Digital printing of polyester has been a major part of the digital boom in the last 10-15 years. In fact, even today nearly half of the estimated 3 billion square meters digital textile printing is by dye-sublimation inks, almost all of it by the transfer route. Machines in this market are usually designed for either transfer or direct printing, but not both, although just a few, including HP's, offer the versatility of a combined solution.

The digital trend itself has been encouraged by the growing demand for personalized and customized products — a desire increasingly satisfied by web-based retailers, offering fabric and garments that are printed to order. And by extension, we should not overlook the influence of mass-market, fast-fashion brands that demand short lead times, a quick turnaround, and frequent style changes.

The multiplicity of uses for polyester is good news for printers. If they can print fabrics for sportswear or fashion, they also have the knowledge and technical capability to explore the many other 'on-demand' markets, such as soft signage, wallpaper, event printing, and the infinite range of promotional products that rely on a polyester coating for their printability.



Digital textile printing is on a boom due to growing demand for personalized products.



### 3. Ease of printing

As we have noted, among the different methods available to print on textiles, **dye-sublimation is the favorite method to print on textiles for its simple process**, in which the image is printed onto a paper roll and then transferred to the textile by means of a heat calender. No need for any pre- or post-treatment. Once printed, the fabric is ready to be shipped.

Seen in close-up, even the finest fabrics have a rough surface compared to a sheet of specially coated transfer paper. When ink is applied directly to the fabric, it tends to diffuse into the pores between the yarns, making the image less crisp and diluting the color strength. That's why direct application of dye-sublimation inks and the closely related disperse-dye inks, require the fabric to be pretreated with a coating that prevents dye migration. Then, after printing, the fabric must be washed to remove the pretreatment chemicals and any unfixed dye. These drawbacks mean the direct method is generally only used by established textile companies that have the necessary equipment, and the use of disperse dyes is mainly limited to soft-signage graphics.



Dye-sublimation transfer, on the other hand, delivers a sharp, bright image in a simple and easy-to-manage process that is attractive to both experienced practitioners and new industry entrants.

This is not to suggest that dye-sublimation transfer printing is always trouble-free. Digital printing requires a harmonious balance between its major elements—hardware, software, inks, and transfer paper. Image quality (IQ) will be the highest priority for the printer and their customers, and when the system fails to deliver, the reason is not always obvious. Many unwary printers, faced with an insoluble quality problem, have found themselves bounced between the hardware and ink suppliers, with each blaming the other for the jam. All but the most technically confident should think carefully before cherry-picking the different elements of their solution from competing suppliers, especially when their selection is based on price alone. It pays to test the full solution in realistic production conditions before making such a crucial decision.







# Challenges in dye-sublimation printing



Color accuracy

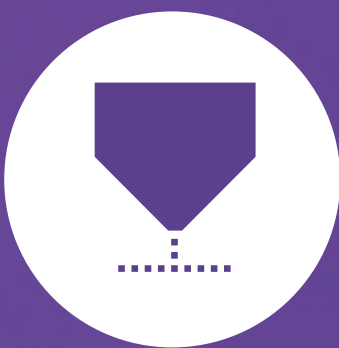

Nozzle outage

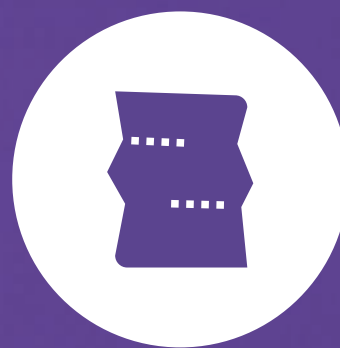

Paper cockling

## 1. Color accuracy

Color accuracy is a critical quality factor and is not always easy to achieve. Customers may send their color specifications as spectral data, PANTONE® references or physical samples, but even if a target color is within the gamut of the print heads and the ink set, matching it precisely may be a process of trial and error, with repeated trips to the lab to analyze print samples by spectrophotometer.

Then there's the need to make sure the colors stay constant throughout the longest of runs. Colors can be affected by several different environmental changes, including humidity and ambient temperature. Unless a print room has sophisticated climate control, color shift can be down to something as simple as a change in the weather.

## 2. Nozzle outage

Of all the most common quality problems, the most frustrating is nozzle outage. The failure of just a few nozzles to fire when called upon can have a devastating effect on the quality of the printed image. And yet there are many reasons why such outage may occur – inadequate maintenance, accidental head strike, ink contamination or coagulation, mechanical failure and electronic faults are just a few. If the problem is not immediately spotted, tens of meters of fabric might go to waste, while diagnosis and repair might cost serious downtime.

## 3. Paper cockling

One frequent problem is paper cockling, caused by the failure of the ink to dry quickly, so that it saturates the paper. This is especially prevalent with the lightweight papers that printers prefer. Residual moisture in the transfer paper can degrade the image as it flashes off in the calender.



# Toward technical solutions

Although there are still some challenges to overcome, printing vendors are working hard to eliminate some of these technical hazards and make the printer's life even easier.

A good example is the new HP STITCH S Printer series. For the first time, a dye-sublimation printer includes a built-in spectrophotometer, which combined with smart color software tools, ensures consistent and stable colors time after time and across the entire HP printer fleet, reducing the iterations that have to be done in order to get the desired color.

Another great innovation of this device is the introduction of a smart nozzle compensation system. Despite the availability of similar methods in the market to prevent nozzle outage, the HP STITCH has a unique thermal inkjet head system with a native resolution of 1200dpi that allows an automatic compensation of up to 30% blocked nozzles without any loss in image quality or printing speed.

As Thermal InkJet technology is less heat sensitive than Piezo, for the first time a dryer could be placed on the printzone. This results in a better cockle control even when using low grammage papers and better sharpness when printing direct-to-fabric.

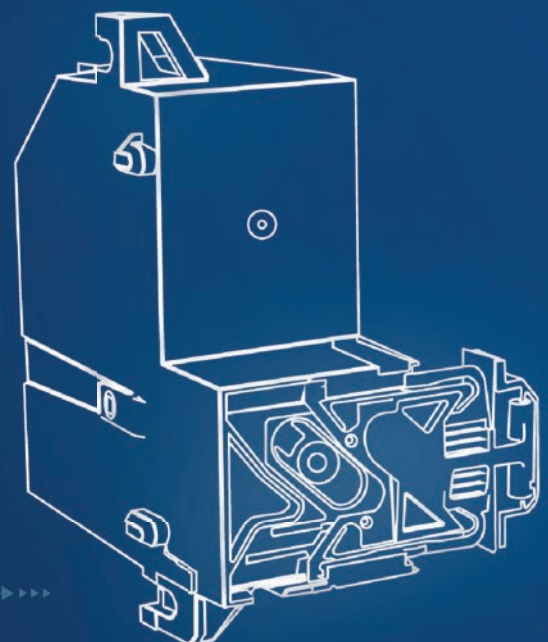

# Conclusion

Printers investing in dye-sublimation technology are acquiring the most important capability in meeting today's rapidly-rising demand trend for customized, on-demand production. Polyester is the world's favorite fiber and its dominance shows no sign of waning. Digital printing of polyester sportswear, in particular, is providing excellent business for on-demand printers all around the world. The advantages of dye-sublimation over other methods of printing polyester are its process simplicity and the brilliance of the colors it produces. It opens the door for printers in the general graphics arena to enter the rapidly expanding textile market.





## References

<sup>1</sup><https://www.wtin.com/article/2018/february/260218/sportswear-market-analysis/>

© Copyright 2020 HP Development Company, L.P.